

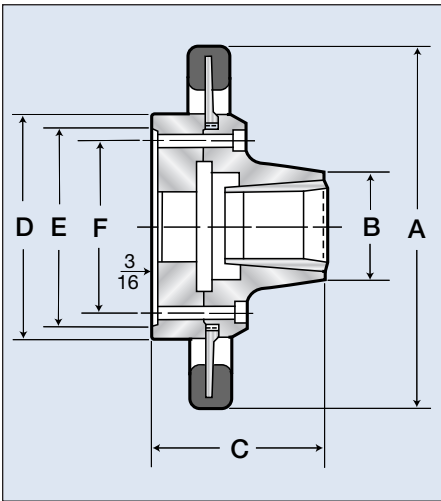

Atlas Workholding Front Hand Wheel Quickie 5C Collet Chucks

- ⊕ Fast and easy, front hand wheel operation
- ⊕ Reduces operator fatigue
- ⊕ Quick Change over Chuck to Collet Chuck - No linkages or drawtubes
- ⊕ For 5C collets
- ⊕ One year warranty
- ⊕ Accurate-Maximum cone TIR .0005"
- ⊕ Available in D type (camlock), A type, L type (long tapered nose) threaded, Flat Back and 4° taper
- ⊕ Hand wheel teeth nitrided for longer life
- ⊕ Body nickel plated for corrosion resistance



Uses 5C Collets see page 112-113

Plain Back Chuck Specifications

Item No.	Desc.	Collet Type	Round Cap.	A	B	C**	D	E	F	Weight
PB23-00	5C-PB	5C	1.06	9.0*	2.25	4.25	5.5	5.0	4.12	

D Type Cam-Lock Chuck Specifications

Item No.	Spindle	Round Cap.	Weight Lbs
PB23-D3	D1-3	1.06	
PB23-D4	D1-4	1.06	
PB23-D5	D1-5	1.06	
PB23-D6	D1-6	1.06	
PB23-D8	D1-8	1.06	
PB23-D11	D1-11	1.06	

A Type American Standard Chuck Specifications

Item No.	Spindle	Round Cap.	Weight Lbs
PB23-A4	A1-4	1.06	
PB23-A5	A1-5	1.06	
PB23-A6	A1-6	1.06	
PB23-A8	A1-8	1.06	
PB23-A11	A1-11	1.06	

L Type American Standard Chuck Specifications

Item No.	Spindle	Round Cap.	Weight Lbs
PB23-L00	L00	1.06	
PB23-L0	L0	1.06	
PB23-L1	L1	1.06	
PB23-L2	L2	1.06	

Threaded Mount Chuck Specifications

Item No.	Spindle	Round Cap.	Weight Lbs
PB23-41	1-1/2-8	1.06	
PB23-42	1-3/4-8	1.06	
PB23-43	2-1/4-8	1.06	
PB23-44	4° Taper	1.06	
PB23-45	2-3/16-10	1.06	
PB23-46	2-3/8-6	1.06	

**Dimension C is chuck without spindle adapter mounting plate. Add approximately 1.125" to dimension C. If exact 'B' Dimension with mounting plate is required contact factory.

HOW TO ORDER: State quantity, Item number and shipping instructions.