

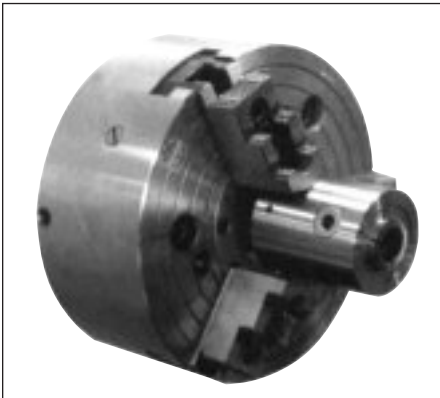

Atlas Workholding Quick Change 5C Collet Chuck

Atlas Model No. COL5C

- ⊕ One-year warranty
- ⊕ Quickly change from chuck work to collet work
- ⊕ Hold the collet chuck O. D. in your power or manual chucks
- ⊕ Mount in vertical mills, horizontal mills and machining centers
- ⊕ Drilled and tapped for fixture mounting
- ⊕ Dead length
- ⊕ Hardened and ground
- ⊕ No set-up
- ⊕ Hex key included

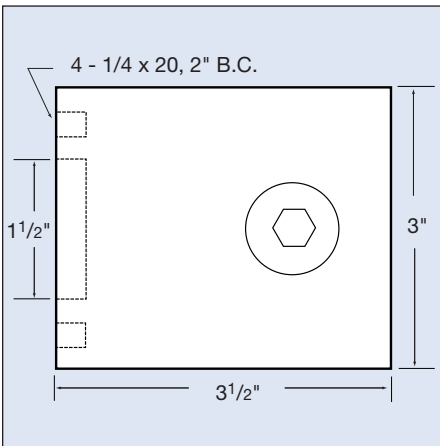

Ideal for short run production on CNC lathes. No tear down or change over

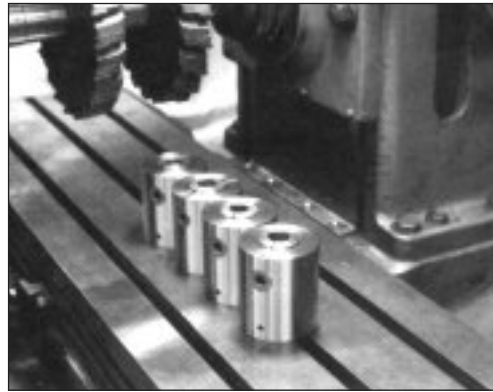

Stack units for multiple part production