



PBA Pratt Burnerd Manual Collet Chucks

Key Operated KC Series

- ⌚ Two-year warranty
- ⌚ .001" repeatability
- ⌚ Capacities from 1/16" through 2 1/2"
- ⌚ Precision manufactured to fit types A, D and L spindles and adapter recess
- ⌚ Steel components are hardened and ground
- ⌚ Simple operation. No drawbar or actuating cylinder required

For KC Collets see page 110

Chuck Size	Capacity	Uses Collet Type	Adapter Recess Model No.	Type A Spindle		Type D Spindle		Type L Spindle	
				Spindle Size	Chuck Model No.	Spindle Size	Chuck Model No.	Spindle Size	Chuck Model No.
KC15	1/16" - 1-1/2"	EC	KC15/AP (6010-01300)			D-3	6012-21300	L-00	6013-11300
				A-5	6011-31300	D-4	6012-31300		
				A-6	6011-41300	D-5	6012-41300	L-0	6013-21300
						D-6	6012-51300		
KC20	1/4" - 2"	ED	KC20/AP (6010-01700)			D-4	6012-31700	L-0	6013-21700
				A-6	6011-41700	D-5	6012-41700		
				A-8	6011-51700	D-6	6012-51700	L-1	6013-31700
						D-8	6012-61700		
KC25	1/2" - 2-1/2"	EE	KC25/AP (6010-02100)			D-6	6012-52100	L-1	6013-32100
				A-6	6011-42100	D-8	6012-62100	L-2	6013-42100
				A-8	6011-52100	D-11	6012-72100		

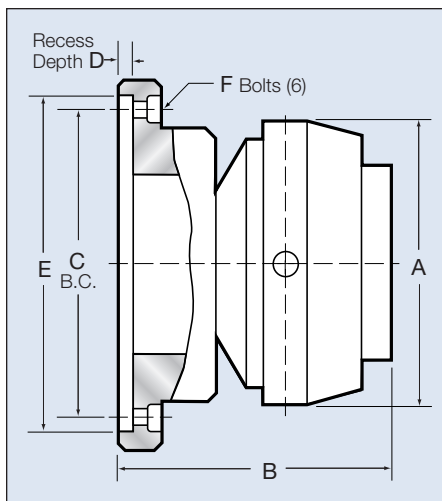

Other mounting available upon request.

Dimensional and Performance Data

Chuck Size	A	B	C	D	E	F	Max rpm	Wt lbs
KC15/AP	4.65	4.56	5.51	.15	4.921	M10	4000	16
KC20/AP	6.00	5.15	6.93	.15	6.299	M10	3000	33
KC25/AP	6.00	5.15	6.93	.15	6.299	M10	3000	30

HOW TO ORDER: State quantity, model number, spindle specification and shipping instructions.